

# STEEL JAWS

- Replacement jaws are available for all vices manufactured by Dawn Tools & Vices Pty Ltd.
- Vertical notch will assist with the holding of non flat objects (note: old style jaws do not have a notch).
- Jaws are case hardened for extra strength.
- Serrated to provide excellent grip.



## Metric Jaws & Bolts (pair)

PART NO.	VICE SIZE JAW WIDTH MM	A MM	B MM	C MM	D - HOLE CENTRES MM	BOLT SIZE MM
65127	75	8	16	77	60	6
65129	100L	10	25	102	75	8
65129	100	10	25	102	75	8
65130	115	15	25	117	90	8
65131	125	15	25	127	100	8
65132	150	15	25	152	125	8
65133	200	15	32	202	175	8



## Metric Jaws & Bolts (pair) with vertical & horizontal slots

PART NO.	VICE SIZE JAW WIDTH MM	A MM	B MM	C MM	D - HOLE CENTRES MM	BOLT SIZE MM
65134	100	10	25	102	75	8
65135	125	15	25	127	100	8
65136	150	15	25	152	125	8
65137	200	15	32	202	175	8

## Imperial Jaws & Countersunk bolts (pair) - old style

PART NO.	VICE SIZE INCHES	A MM	B MM	C MM	D - HOLE CENTRES INCHES	C/ SUNK BOLT SIZE MM
65150	3	8	16	77	1 1/2	6 C/Sunk
65152	4L	10	22	102	2 3/16	6 C/Sunk
65153	4	10	25	102	2 1/2	6 C/Sunk
65154	4 1/2	15	25	117	2 3/4	6 C/Sunk
65155	5	15	25	127	3	8 C/Sunk
65156	6	15	25	152	4 1/8	8 C/Sunk
65157	8	15	32	202	4 1/2	8 C/Sunk

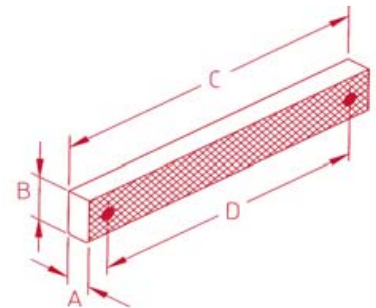

## FORGED Utility Vice Jaws & Bolts (pair)

PART NO.	VICE SIZE MM	A MM	B MM	C MM	D - HOLE CENTRES	BOLT SIZE
65140	100	11	20	100	70	8
65141	125	13	25	125	90	8
65142	150	13	28	150	110	10
65143	175	13	28	175	110	10